

SERIES 83 2 PANEL PATIO DOOR INSTALLATION

REV 3/2026

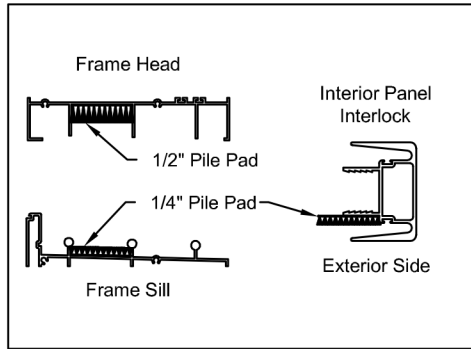

1. Install the 1/2" tall adhesive weather-strip pad in the center of the frame head between the vertical guides legs as shown above.
2. Install a 1/4" tall adhesive weather-strip pad in the center of the frame sill between the two roller tracks as shown above. Install a 1/4" tall adhesive weather-strip pad at the bottom exterior side interlock of the interior panel.

Note: The weatherstrip pads should be in line with the interlocks when the door is completely assembled.

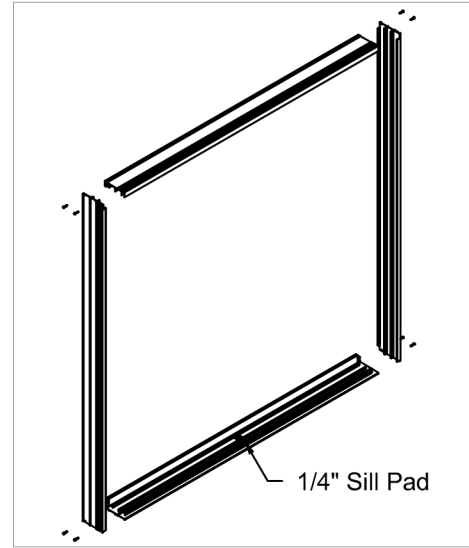

3. Assemble the door frame using the #8 X 1" zinc pan head screws (8).

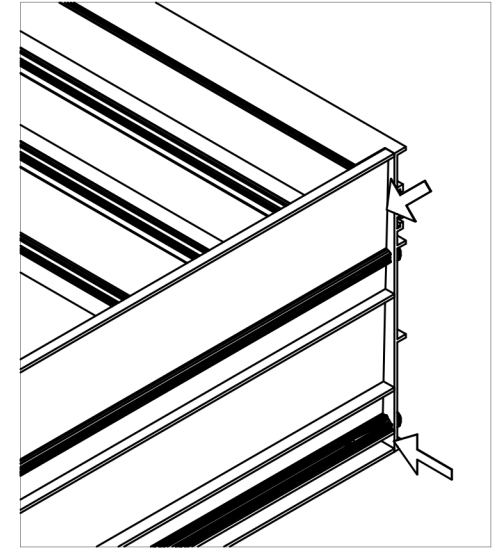

4. Caulk the bottom of the frame sill to jamb joint making sure the pocket created by the sill dam is filled with sealant.
5. Install the frame in the opening per Alenco instruction detail 1-4 780-1 (finless frame) or 1-4780-2 (nail fin version)

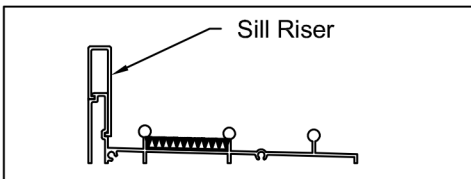
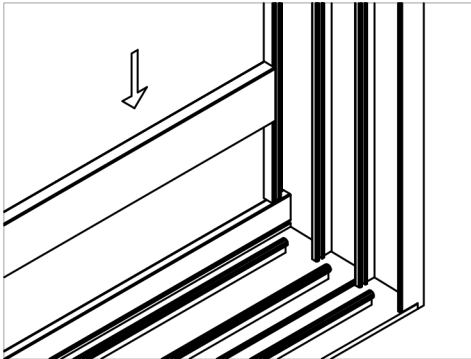

6. If the sill riser is required use a rubber mallet to drive it over the dam of the frame sill.

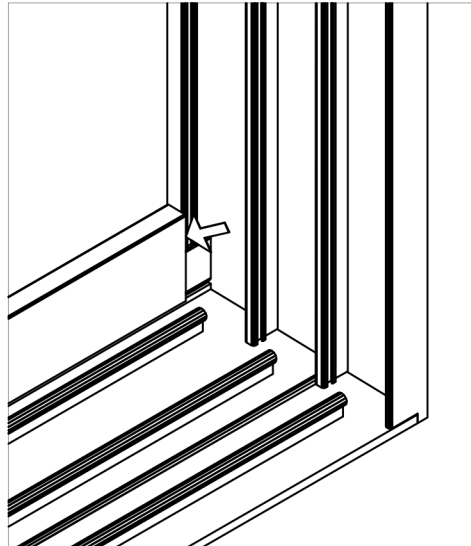

7. If the sill riser is added sealant must be applied from the top of the riser to jamb joint down to the frame sill.

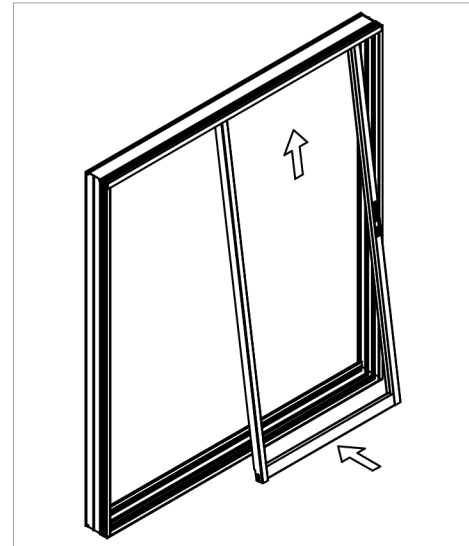

8. Install the inside vent first. The vent installs from the outside. Push the top of the vent up into the head and swing the bottom onto the sill.

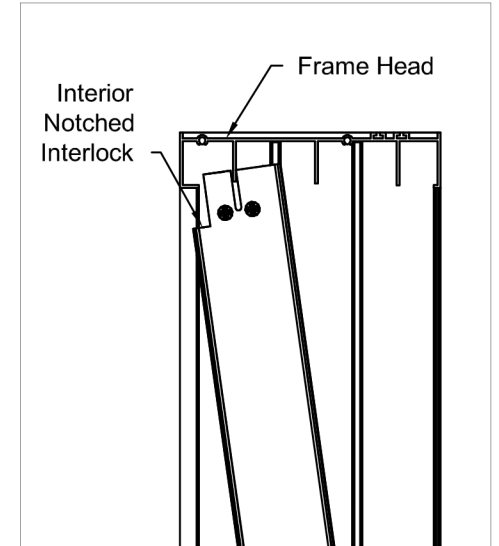

Note: The interior vent will have the interlock notched back at the head and sill. The head end of an XXR or OX configuration is shown in the figure above.