

**SERIES 83  
XXX 3 PANEL  
PATIO DOOR  
INSTALLATION**

REV 3/2026

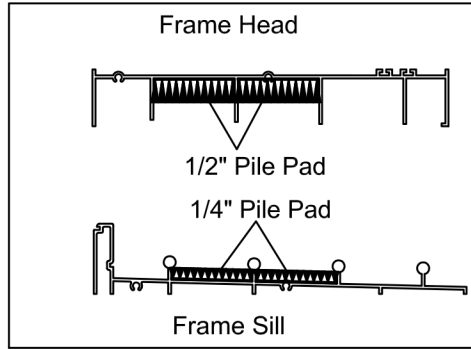

1. Install one 1/2" tall adhesive weatherstrip pad 1/3 from each end on the frame head between the vertical guides legs as shown above.
2. Install one 1/4" tall adhesive weatherstrip pad 1/3 from each end on the frame sill between the roller tracks as shown above.

Note: The weatherstrip pads should be in line with the interlocks when the door is completely assembled.

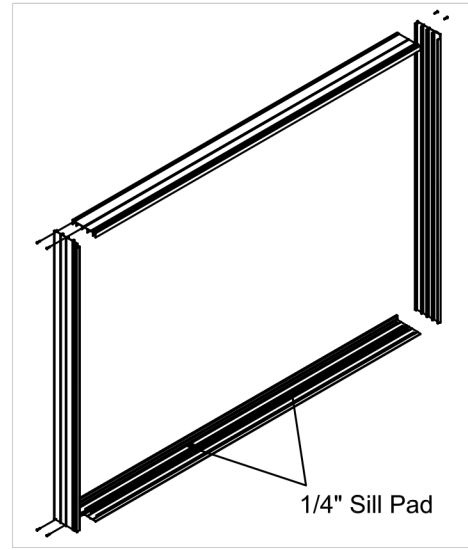

3. Assemble the door frame using the #8 X 1" zinc pan head screws (8).

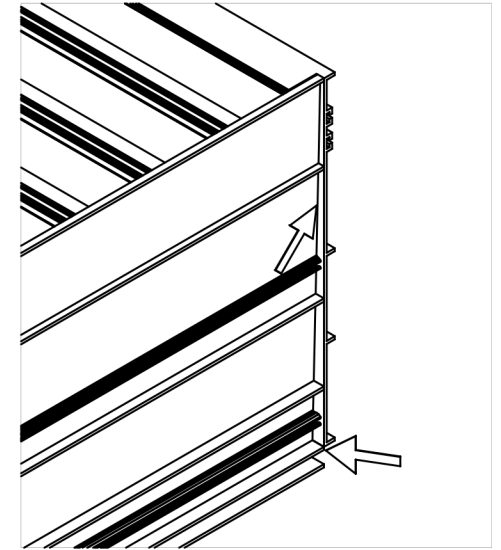

4. Caulk the bottom of the frame sill to jamb joint making sure all joints between sill and jamb are filled with sealant.
5. Install the frame in the opening per Alenco instruction detail 1-4780-1 (finless frame) or 1-4780-2 (nail fin version)

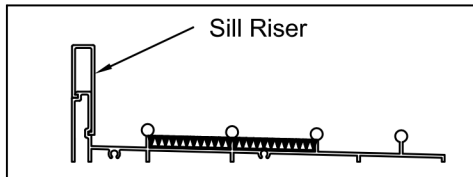
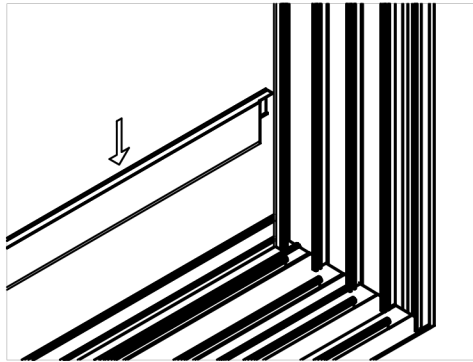

6. If the sill riser is required use a rubber mallet to drive it over the dam of the frame sill.

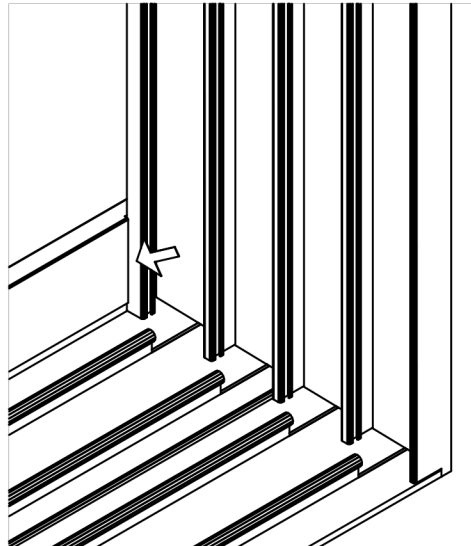

7. If the sill riser is added sealant must be applied from the top of the riser to jamb joint down to the frame sill.

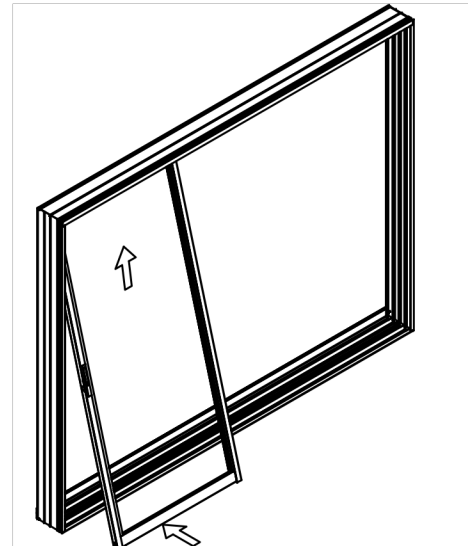

8. Install the inside vent first. The vent installs from the outside. Push the top of the vent up into the head and swing the bottom onto the sill.

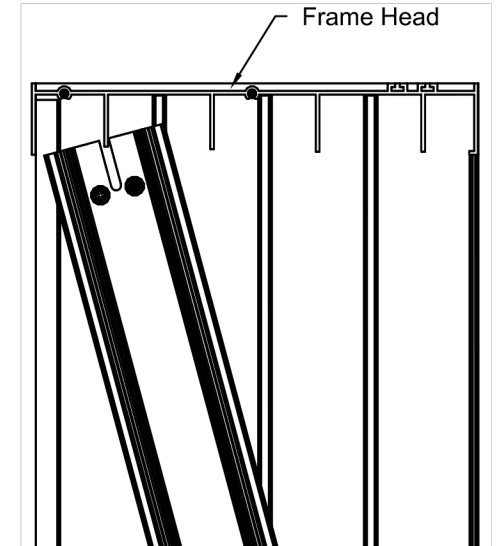

Note: The figure above shows the inside vent being inserted into the interior track.

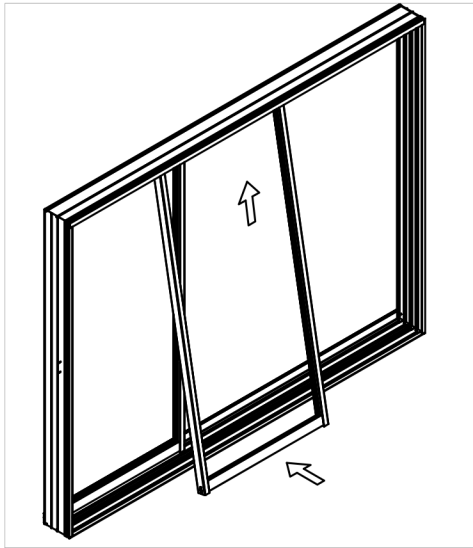

9. Install the center vent next. This vent has interlocks on both sides. From the outside push the top of the vent up into the second track (from inside) of the head and swing the bottom onto the sill.

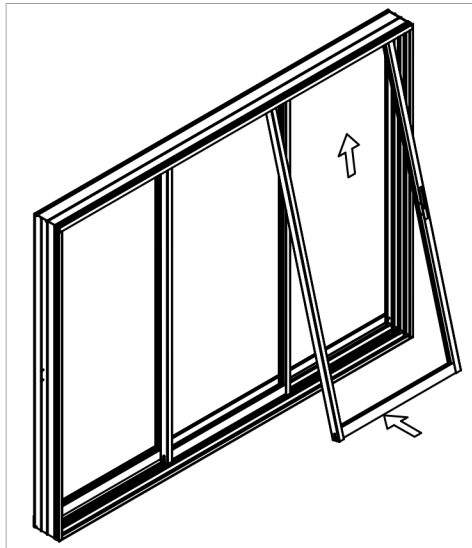

10. Next install outside vent. From the outside push the top of the head and swing the bottom onto the sill.

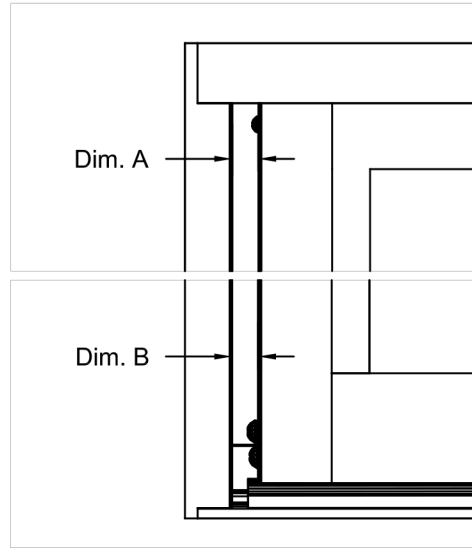

11. Move a vent up to the frame and measure the gap at the head and at the sill. (Dim. A and Dim. B)

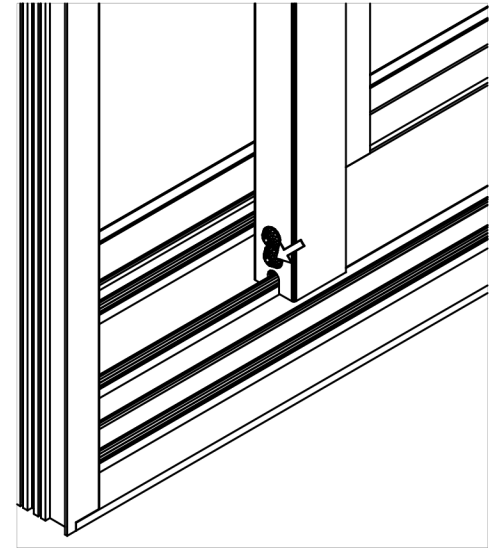

12. Use the roller height adjustment screws to raise and lower either end of the vent until Dim. A and Dim. B are equal. Repeat steps 11 and 12 for the other vents.

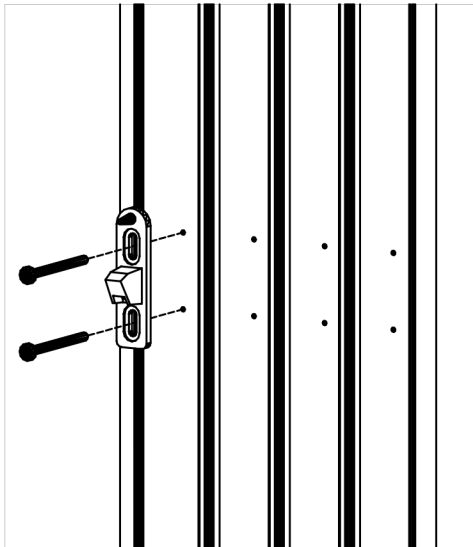

13. Install the keepers in the frame jambs using the predrilled holes as shown above. Attach using the 1" long phil head screws and be sure to place a shim behind the jamb at each keeper location. Adjust the keeper vertically until the throw of the lock fully engages the keeper.

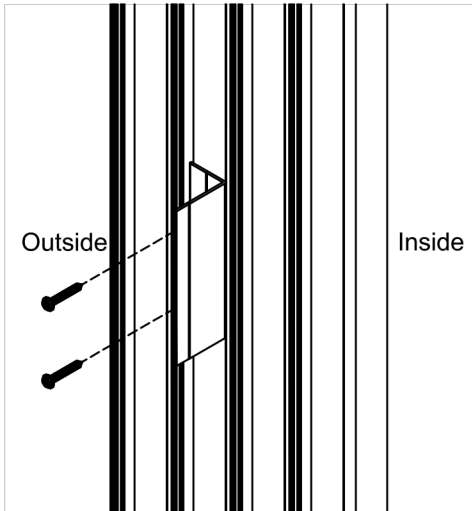

14. Install two O-Panel Clips in the frame jamb as shown. Space the clips approximately 1/4 of the door height down from the head and 1/4 of the door height up from the sill. Use 2 #8 X 1" self drilling screws per clip.

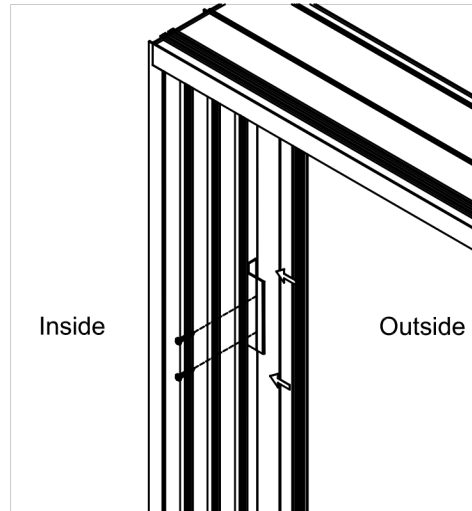

15. Complete the O-Panel installation by inserting the panel into the frame jamb and attaching the clip to the panel using 2 #8 X 1" self drilling screws per clip.

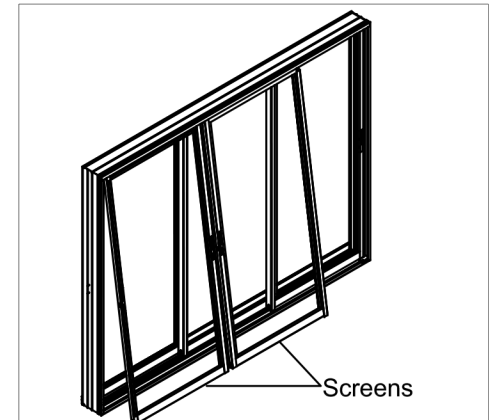

16. Install the screens from the outside so that they operate the same direction as the interior vents. To install the screens push the top of the vent up into the outer most track of the head (as shown above) and swing the bottom onto the sill. Adjust the screens just as you did the vents in steps 11 and 12 and then install the keeper in the jamb as shown in step 13. Install keeper between two screens with two #7 x 7/16" self drill screws.

**Note: Steps 14 and 15 apply to XXX doors with one end fixed.**

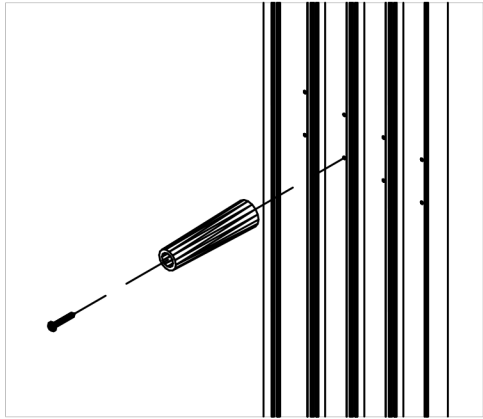

17. Install the frame bumper in the second jamb track opposite operating vents with one (1) #8 x 1" self drilling screw.

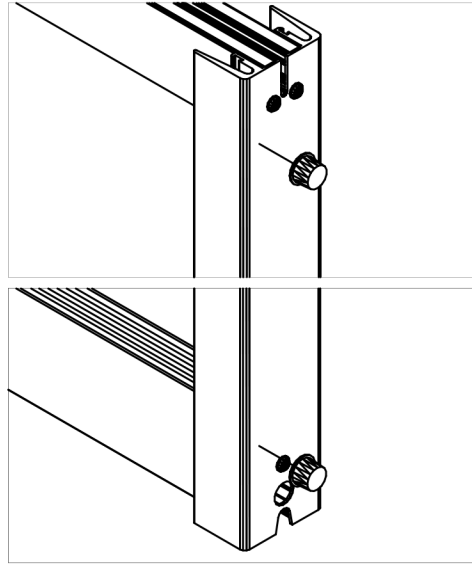

18. Install the self adhesive panel bumpers to interior and exterior panels at the top or bottom of the interlocks as shown above. Be sure to align them along the edge of the interlock closest to the center panel to assure bumper will make contact with center panel interlock when panel is fully opened.

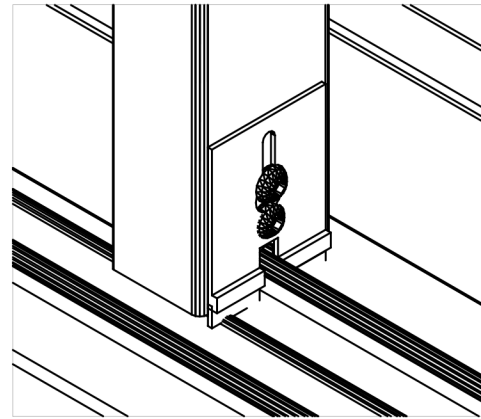

19. Optional: Install bug sweep at bottom of interlocks interior and exterior. To install back out bottom panel screw 2-3 turns or enough to slip bug sweep over and under screw head. Adjust and tighten screw.

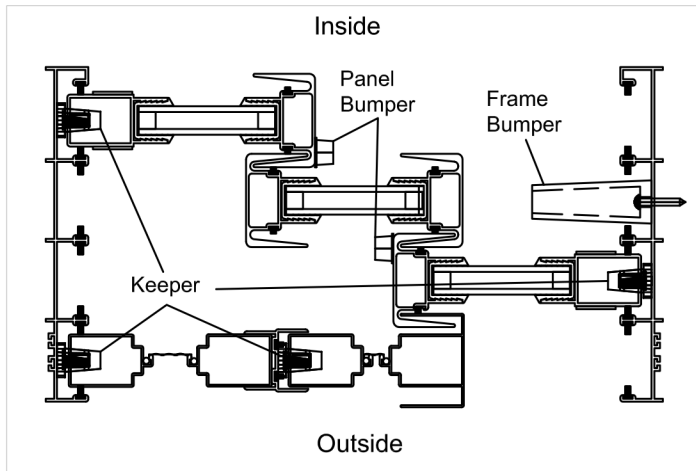

Note: Above picture shows bumper and keeper locations for XXX door.