

# SERIES 85 BYPASS SLIDING DOOR INSTALLATION

## Pre-Assembly:

Prior to installation of this sliding patio door system, it is recommended to read the instructions pertaining to the specific configuration of the unit being installed.

## Recommended Tool Requirements (Not Supplied by Manufacturer):

- 1) Rubber Mallet
- 2) Level (3' or larger)
- 3) Florida Approved Installation Fasteners  
(See FL Approval for Size & Spacing)
- 4) Load Bearing Shims
- 5) Perimeter Sealant

**Note:** Sealant shall conform to Fed. Spec. TTs-S-00230C Type II Class, ASTM C920 Type S, Grade NS class 25, AAMA 808.3-92 exterior perimeter sealing compound.

**Step 1. (Inspection)** Carefully remove all packaging, frame components, and hardware from the patio door frame pack. Verify that all components shown in the parts list on the final pages of these instructions have been accounted for and are in good working condition.

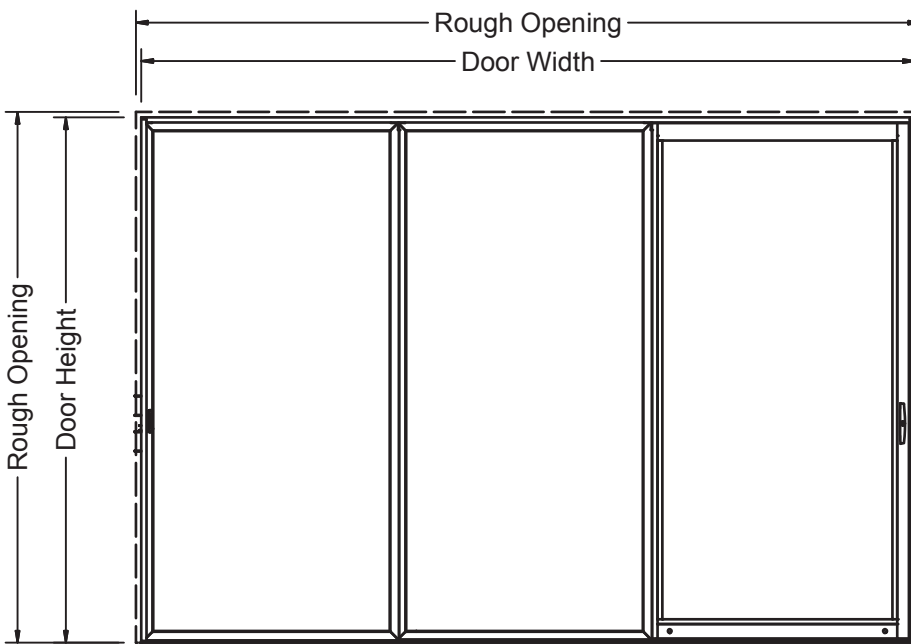

Figure 1.

**Step 2. (Preparation)** Verify that the rough opening is level, plumb, square, and clear of any obstructions. Also, verify that the unit assembled door size and rough opening coincide with one another. This task can be accomplished by measuring the individual frame assembly and the rough opening separately (See Note). The rough opening width should not exceed the door width by more than 1/2". Similarly, the rough opening height should not exceed the door height by more than 1/4" (See Figure 1).

**Note:** Measuring the individual components (head / jamb / sill) might be more suitable for larger units. The frame jamb should be equal to the unit height, while the frame head and sill will be 5/8" less than the overall frame width.

## Frame Assembly (ByPass Door):

**Step 3. (Frame Assembly)** Gather the frame head, sill and jambs required for bypass door assembly. Align frame assembly holes of the jamb with the screw bosses on the head and sill profiles. Assemble the door frame using the provided #8 x 1 1/2" Hex Washer Head screws. Complete this process at all four corners of the door frame before continuing (See Figures 2 and 2A).

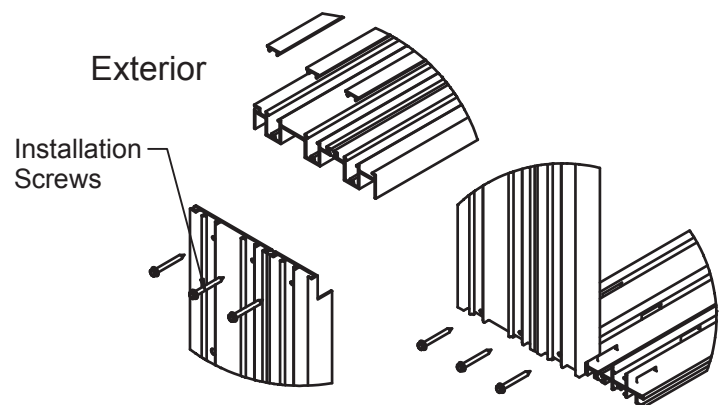

Figures 2 and 2A.

Interior

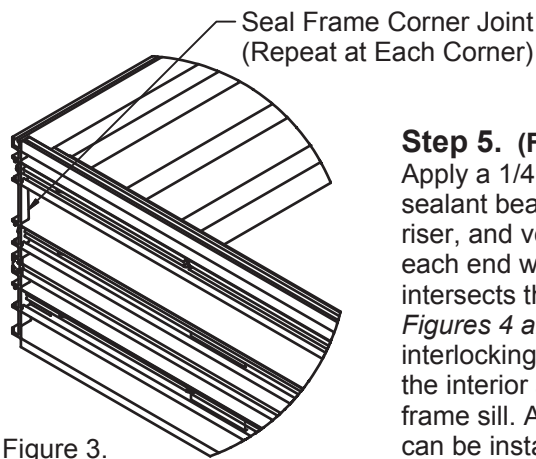
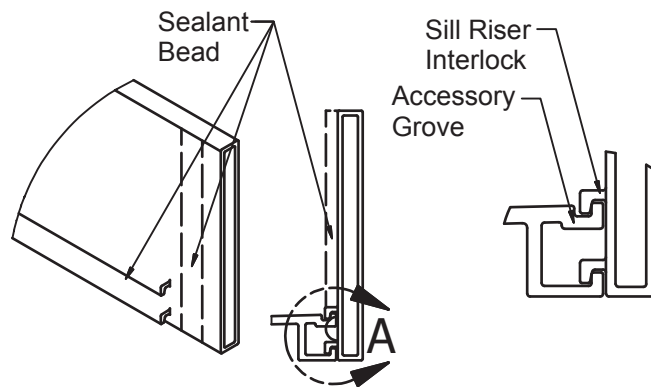

Figure 3.

**Step 4. (Frame Assembly Cont.)** Apply a generous bead of sealant along the frame sill to frame jamb joint on the bottom side of the frame assembly. Repeat this procedure at all four corners of the bypass door assembly before proceeding to the next step (See Figure 3).

**Step 5. (Frame Assembly Cont.)**

Apply a 1/4" diameter horizontal sealant bead full length of the sill riser, and vertical sealant bead at each end where the sill riser intersects the frame jamb (See Figures 4 and 4A). Insert the interlocking end of the sill riser into the interior accessory groove on the frame sill. Alternatively, the sill riser can be installed after the door frame provided there is a minimum of 1/2" clearance between the door frame and foundation.



Figures 4 and 4A.

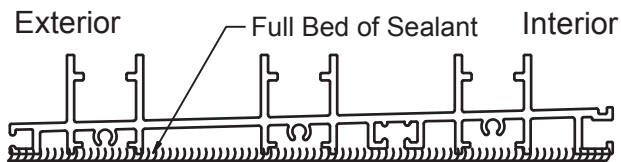

Figure 5.

**Installation (ByPass Door):**

**Step 6. (Installation)** Place assembled frame unit in bed of sealant full length of the frame sill (See Figure 5). If the installer chooses to install the sill riser after the frame has been placed in the rough opening, ensure that sufficient room is available.

**Step 7. (Shimming)** Once the frame has been placed in the rough opening, verify that the frame is plumb and square. Shim underneath all installation fasteners at the frame head and frame jambs. During the shimming process, continually check that the frame is plumb and square.

**Step 8. (Fastening)** Attach the door frame to the opening through the pre-punched installation holes at the head, jambs, and sill. Fill each installation hole with sealant prior to fastener insertion. Once all fasteners have been installed, seal all screw heads applied through the frame sill.

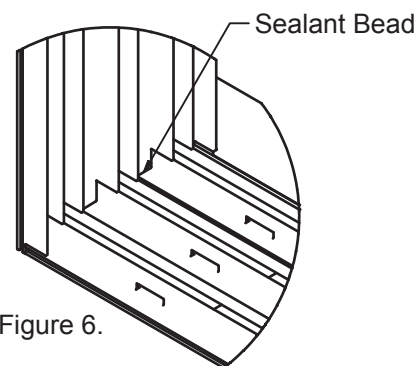

Figure 6.

**Note:** See Florida Approval for the correct fastener type, quantity and minimum embedment of the applicable construction.

**Step 9. (Frame Corner Sealant)** Once all installation screws have been properly installed, apply a bead of sealant and tool at both frame sill to frame jamb joints (See Figure 6).

**Step 10. (Foam Sponge Installation)** Compress and insert the reticulated foam sponge provided in the frame hardware pack. Placement of the sponge should fully cover the interior weep of the frame sill. Complete this process at each weep location for all roller track cavities (See Figure 7).

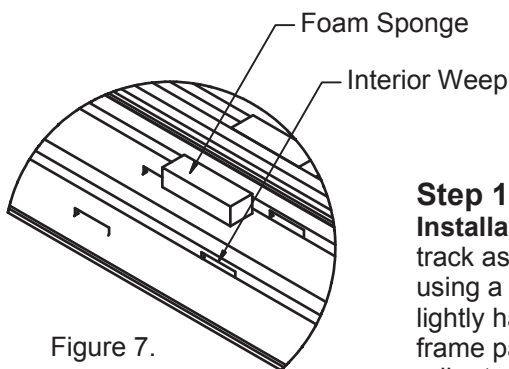

Figure 7.

**Step 11. (Roller Track Installation)** Install the roller track as shown in Figure 8, using a rubber mallet and lightly hammering. The door frame pack will come with one roller track per panel.

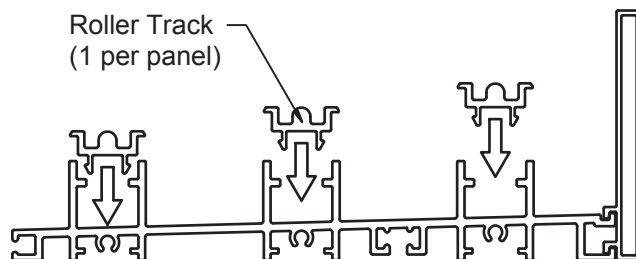
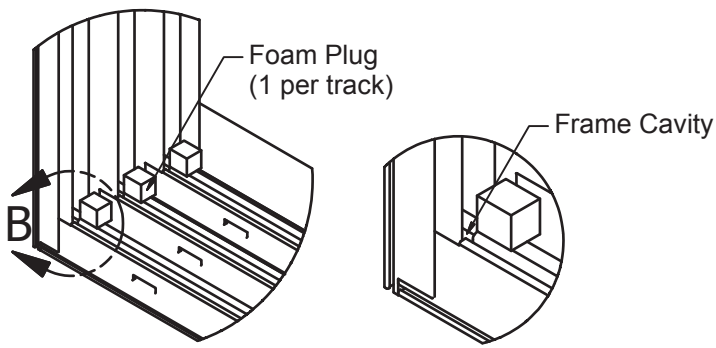

Figure 8.



Figures 9 and 9A.

**Step 13. (Panel Installation)** ByPass doors will be supplied with one exterior vent (XRE / XLE), one interior vent (XRI / XLI), and the remaining vents will be center vents (XC). The vent type will be noted on the production label, or you can reference the configurations at the end of these instructions. Insert the interior vent by slipping the panel head rail over the accompanying frame head track and rotating the bottom of the panel inward. Once the panel is vertical, lower the panel and ensure that the rollers are properly seated on the roller track. Each panel should be installed with the roller adjustment holes facing the exterior.

**Step 14. (Panel Installation Cont.)** Once the interior panel has been properly installed, repeat Step 13 for each center door panel (if required). Similarly, install the exterior panel, which will complete the panel installation process.

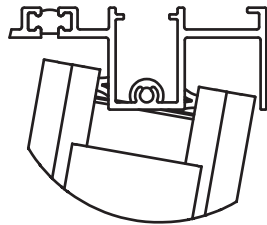

**Note:** The interior and exterior panels will have a single interlock, while the center panels will have a double interlock.

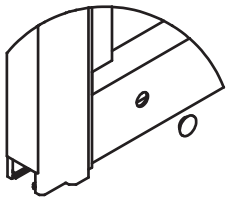
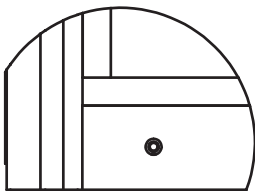

Figures 10 and 10A.

**Step 12. (Foam Plug Installation)** Remove the liner of the adhesive back dust plug provided in the hardware frame pack. Insert the plug into the cavity between the roller track and frame jamb (See Figures 9 and 9A).

**Note:** There will be one dust plug provided for each roller track / frame jamb cavity.

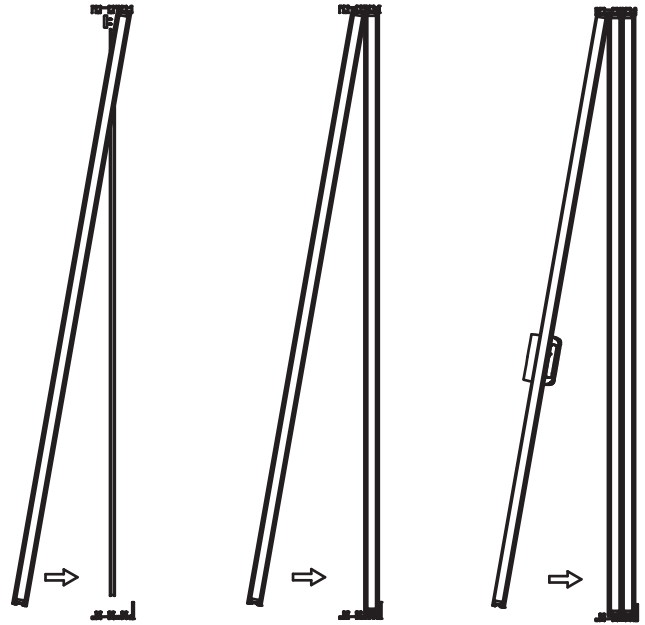

Panel Installation (2 and 4 Panel Doors Similar)

**Step 15. (Panel Adjustment)** Adjust the panels by using a phillips head screw driver and turning clockwise (raise panel) or counter clockwise (lower panel). Adjust all door panels until all sight lines are even and the panels operate freely. **DO NOT** use a drill or impact driver to adjust the rollers, as this may cause damage to the roller.

**Note:** Due to the weight of the panels, it is recommended to lift the panel corner being adjusted to prevent damage to the roller adjustment screw.

**Step 16. (Hole Plug Installation)** Cover the roller adjustment holes with the supplied 1/2" hole plug (See Figures 10 and 10A).

**Step 17. (Dust Plug Installation)** Place the fin seal dust plug directly underneath each interlock at the head and sill ends (See Figure 11).

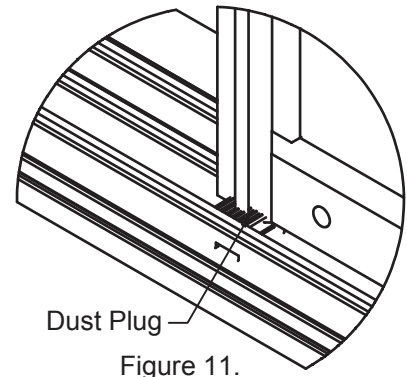

Figure 11.

## Hardware Installation

**Step 18. (Keeper Installation)** To complete the frame installation, use the supplied #8 x 2 1/2" stainless steel phillips pan head screws to install the dual mortise keeper. There will be dimples in the frame jambs to help locate the keeper (See Figure 12). Install the keeper at each frame jamb before proceeding to the next step.

**Note:** Each jamb cavity will contain dimples, but the keeper should only be installed with the adjoining locking panels.

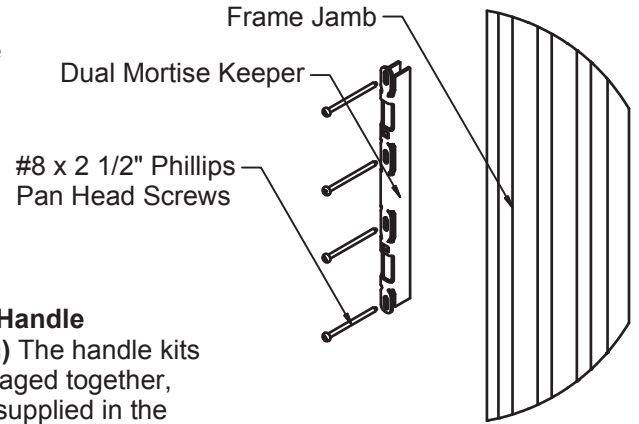

Figure 12.

### Step 19. (Handle Installation)

The handle kits will be packaged together, and will be supplied in the frame hardware pack. Insert the tail of the thumb latch into to accompanying slot on the mortise. Secure the interior and exterior handle using the oval head fasteners supplied in the handle set. Handle installation will be required for both the interior and exterior panels (See Figure 13).

**Note:** Be sure the handle is securely fastened, but be aware not to overtighten the assembly screws. Also, the mortise will not activate unless the safety pin is engaged

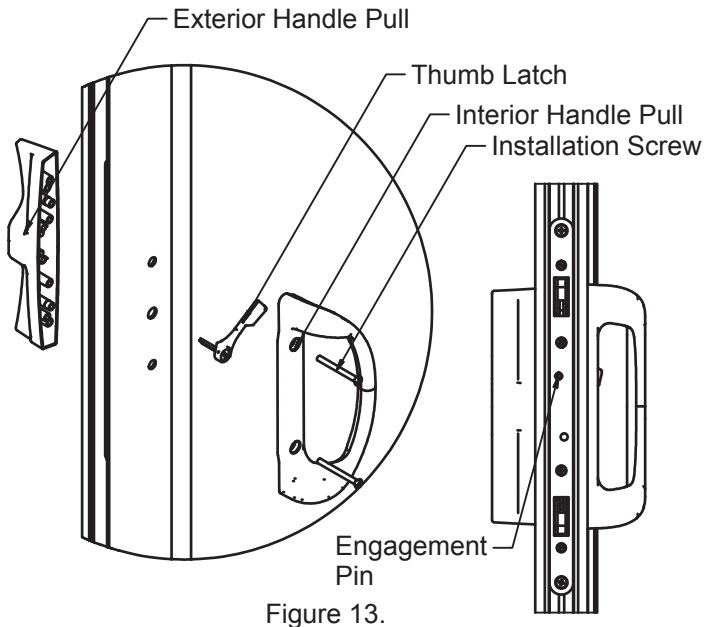
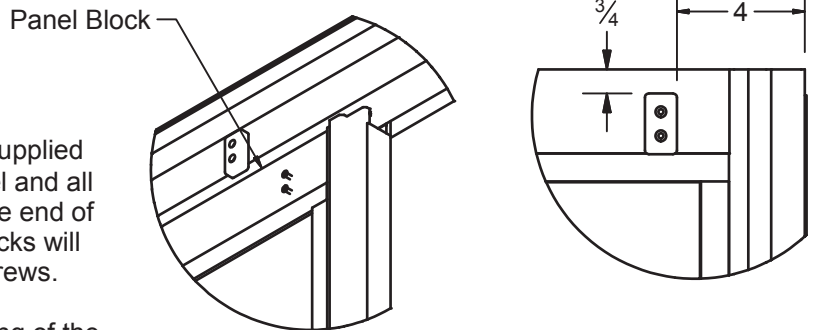

Figure 13.

**Step 20. (Panel Bumper Block Installation)** Apply the supplied panel bumper block in the upper corner of the interior panel and all center panels (if required). Placement should be 4" from the end of the panel and 3/4" from the top of the panel. The panel blocks will be fastened using the provided #8 x 1" phillips flat head screws.

**Note:** The panel bumper blocks are used to prevent clashing of the panels. Installation will not be required for the exterior panel.



Figures 14 and 14A.

## Screen Installation (Optional)

**Step 1. (Inspection)** ByPass doors will come supplied with the necessary tracks for screen installation. Inspect the screen frame to ensure there is no damage and that the parts are cut to the correct length. The screen track head and sill should be the over door width, while the screen track jambs should be 5/8" less than the door height.

**Step 2. (Preparation)** Ensure that the exterior accessory groove is clear of debris. Clear any obstructions from the accessory groove and frame opening before continuing.

**Note:** Screen track installation must be completed before the final perimeter seal is applied.

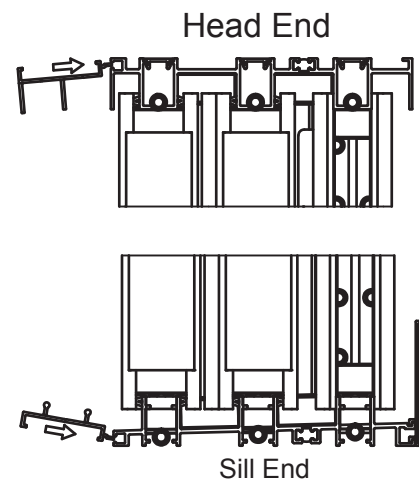

Figure 15.

**Step 3. (Screen Track Installation)** Insert the tongue of the screen sill track into the frame sill accessory groove and rotate downward until the screen track makes contact with the foundation. Repeat this procedure at the head before proceeding (See Figure 15).

**Step 4. (Screen Track Installation Cont.)** Shim underneath the head screen track and ensure that the track is level with the door frame head. Secure the screen sill track and head screen track to the rough opening using the fasteners of the installers choice. There are no specific fastener requirements for the screen track installation, but it is recommended that the fastener placement be 24" O.C. with sufficient embedment to properly secure the tracks.

**Step 5. (Screen Track Installation Cont.)** Repeat steps 3 and 4 for each jamb screen track. Verify that each jamb corner mates properly with the head and sill screen tracks before fastening to the rough opening (See Figure 16).

**Step 6. (Screen Track Corner Sealant)** Once all installation screws have been properly installed, apply a bead of sealant and tool at both screen sill track to screen jamb track joints.

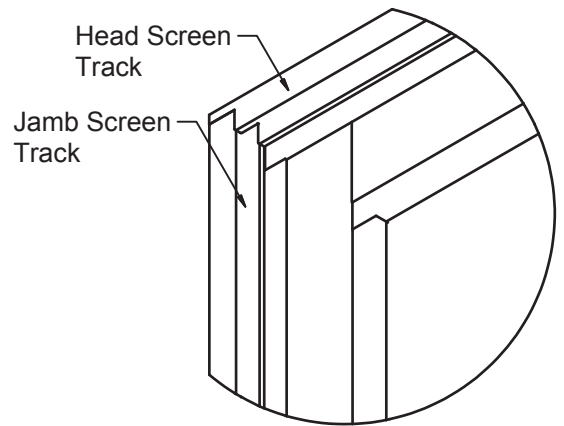

Figure 16.

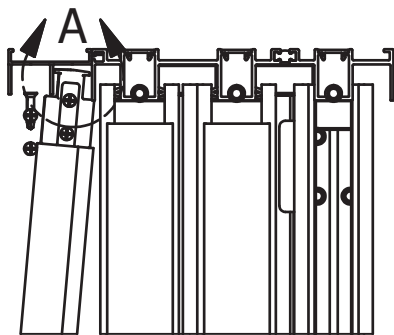
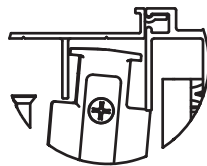

Figure 17.



**Step 7. (Screen Installation)** Insert the head end of the screen frame into the innermost screen track channel and rotate the screen inward (See Figure 17). Repeat this procedure for each screen, working from interior to exterior.

**Note:** ByPass doors will come with one less screen than operating door panel. Please refer to the door configurations at the end of these instructions for proper screen placement.

**Step 8. (Screen Adjustment)** Adjust each screen as necessary to ensure proper alignment and ease of operation. The screen adjustment will be located at each end of the screen frame.

**Step 9. (Screen Keeper Installation)** Install the patio door screen keeper at the correct screen jamb track using the supplied #6 x 3/4" phillips flat head screws (See Figure 18). The keeper will always be installed in the outermost screen track channel. Verify proper alignment with the screen prior to installing the screws.

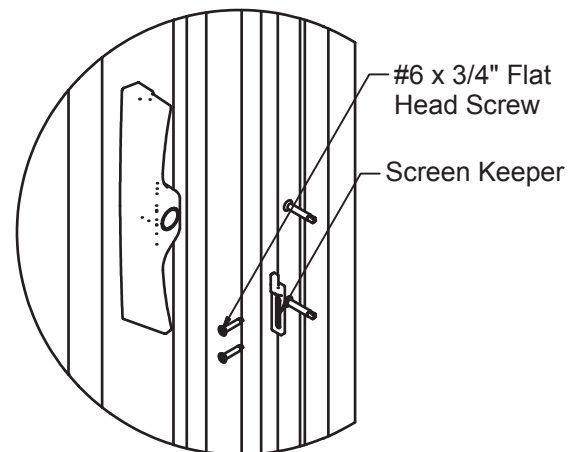
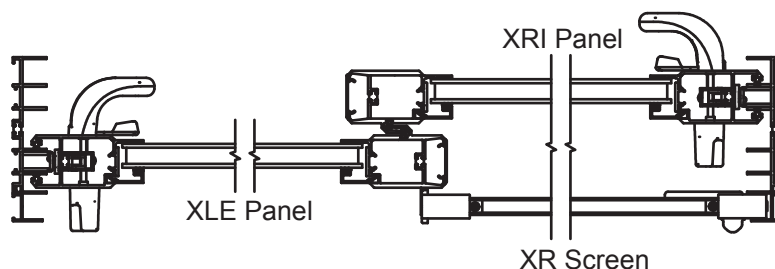

Figure 18.

# ByPass Door Parts Lists

## XXL ByPass Door



## XXR ByPass Door

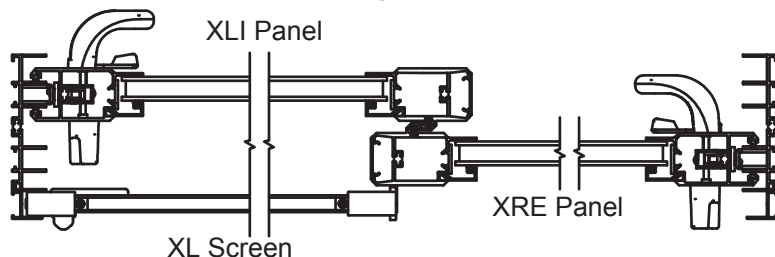

## White

Part No.	Quantity	Color	Description
460031005	2	White	Interior / Exterior Handle Set
420122000	2	Stainless Steel	Dual Mortise Keeper
430022005	1	Zinc	Patio Door Screen Keeper
430031005	1	White	Panel Bumper Block
279751	4	White	Roller Adjustment Hole Plug
440031000	2	Stainless Steel	#6 x 3/4" Ph Flt Hd Screen Keeper Installation Screw
440037005	2	White	#8 x 1" Ph Flt Hd Panel Bumper Block Installation Screw
440026000	8	Stainless Steel	#8 x 1 1/2" Hex Hd Frame Assembly Screw
440027000	8	Stainless Steel	#8 x 2 1/2" Ph Pn Hd Keeper Installation Screw
166609	10	Black	1.25" x 0.5" x 2" Reticulated Foam Bug Sponge
600036010	2	Grey	0.625" x 1.5" x 1.188" Head / Sill Interlock Dust Plug
600037010	4	Black	0.680" x 0.635" x 0.75" Frame Jamb / Roller Track Foam Plug

## Bronze / Adobe Grey

Part No.	Quantity	Color	Description
460031018	2	Black	Interior / Exterior Handle Set
420122000	2	Stainless Steel	Dual Mortise Keeper
430022018	1	Zinc	Patio Door Screen Keeper
430031018	1	Black	Panel Bumper Block
643209	4	Black	Roller Adjustment Hole Plug
640631	4	Adobe Grey	Roller Adjustment Hole Plug
440031000	2	Stainless Steel	#6 x 3/4" Ph Flt Hd ScreenKeeper Installation Screw
440037018	2	Black	#8 x 1" Ph Flt Hd Panel Bumper Block Installation Screw
440026000	8	Stainless Steel	#8 x 1 1/2" Hex Hd Frame Assembly Screw
440027000	8	Stainless Steel	#8 x 2 1/2" Ph Pn Hd Keeper Installation Screw
166609	10	Black	1.25" x 0.5" x 2" Reticulated Foam Bug Sponge
600036010	2	Grey	0.625" x 1.5" x 1.188" Head / Sill Interlock Dust Plug
600037010	4	Black	0.680" x 0.635" x 0.75" Frame Jamb / Roller Track Foam Plug

# ByPass Door Parts Lists

## XXXL ByPass Door

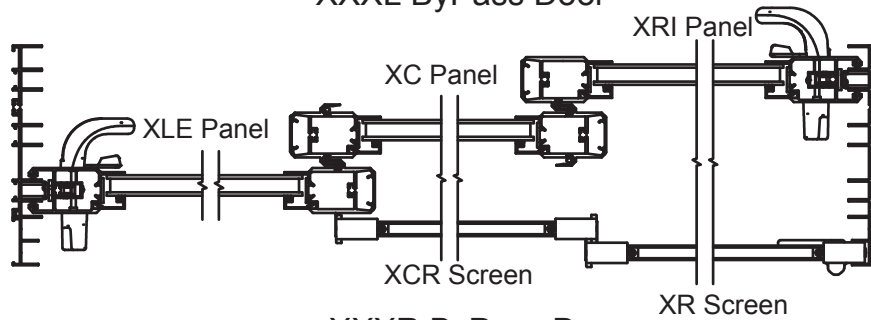

## XXXR ByPass Door

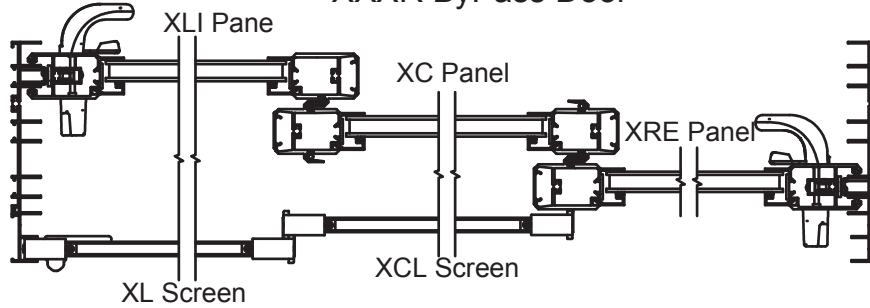

## White

Part No.	Quantity	Color	Description
460031005	2	White	Interior / Exterior Handle Set
420122000	2	Stainless Steel	Dual Mortise Keeper
430022005	1	Zinc	Patio Door Screen Keeper
430031005	2	White	Panel Bumper Block
279751	6	White	Roller Adjustment Hole Plug
440031000	2	Stainless Steel	#6 x 3/4" Ph Fit Hd Screen Keeper Installation Screw
440037005	4	White	#8 x 1" Ph Fit Hd Panel Bumper Block Installation Screw
440026000	12	Stainless Steel	#8 x 1 1/2" Hex Hd Frame Assembly Screw
440027000	8	Stainless Steel	#8 x 2 1/2" Ph Pn Hd Keeper Installation Screw
166609	20	Black	1.25" x 0.5" x 2" Reticulated Foam Bug Sponge
600036010	4	Grey	0.625" x 1.5" x 1.188" Head / Sill Interlock Dust Plug
600037010	6	Black	0.680" x 0.635" x 0.75" Frame Jamb / Roller Track Foam Plug

## Bronze / Adobe Grey

Part No.	Quantity	Color	Description
460031018	2	Black	Interior / Exterior Handle Set
420122000	2	Stainless Steel	Dual Mortise Keeper
430022018	1	Zinc	Patio Door Screen Keeper
430031018	2	Black	Panel Bumper Block
643209	6	Black	Roller Adjustment Hole Plug
640631	6	Adobe Grey	Roller Adjustment Hole Plug
440031000	2	Stainless Steel	#6 x 3/4" Ph Fit Hd ScreenKeeper Installation Screw
440037018	4	Black	#8 x 1" Ph Fit Hd Panel Bumper Block Installation Screw
440026000	12	Stainless Steel	#8 x 1 1/2" Hex Hd Frame Assembly Screw
440027000	8	Stainless Steel	#8 x 2 1/2" Ph Pn Hd Keeper Installation Screw
166609	20	Black	1.25" x 0.5" x 2" Reticulated Foam Bug Sponge
600036010	4	Grey	0.625" x 1.5" x 1.188" Head / Sill Interlock Dust Plug
600037010	6	Black	0.680" x 0.635" x 0.75" Frame Jamb / Roller Track Foam Plug

# ByPass Door Parts Lists

## XXXXL ByPass Door

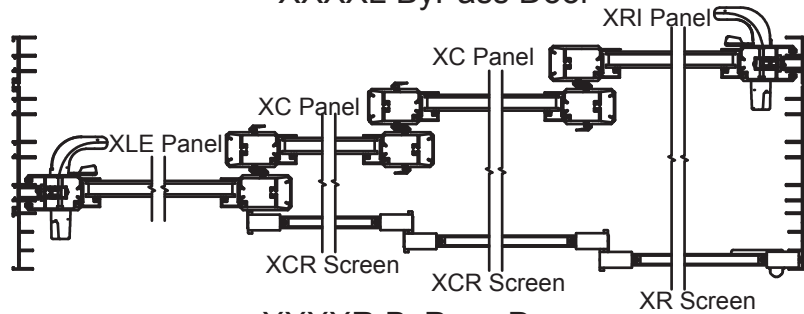

## XXXXR ByPass Door

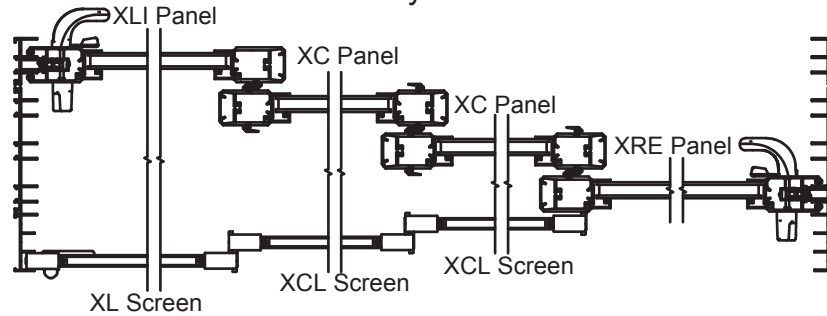

## White

Part No.	Quantity	Color	Description
460031005	2	White	Interior / Exterior Handle Set
420122000	2	Stainless Steel	Dual Mortise Keeper
430022005	1	Zinc	Patio Door Screen Keeper
430031005	3	White	Panel Bumper Block
279751	8	White	Roller Adjustment Hole Plug
440031000	2	Stainless Steel	#6 x 3/4" Ph Fit Hd Screen Keeper Installation Screw
440037005	6	White	#8 x 1" Ph Fit Hd Panel Bumper Block Installation Screw
440026000	16	Stainless Steel	#8 x 1 1/2" Hex Hd Frame Assembly Screw
440027000	8	Stainless Steel	#8 x 2 1/2" Ph Pn Hd Keeper Installation Screw
166609	30	Black	1.25" x 0.5" x 2" Reticulated Foam Bug Sponge
600036010	6	Grey	0.625" x 1.5" x 1.188" Head / Sill Interlock Dust Plug
600037010	8	Black	0.680" x 0.635" x 0.75" Frame Jamb / Roller Track Foam Plug

## Bronze / Adobe Grey

Part No.	Quantity	Color	Description
460031018	2	Black	Interior / Exterior Handle Set
420122000	2	Stainless Steel	Dual Mortise Keeper
430022018	1	Zinc	Patio Door Screen Keeper
430031018	3	Black	Panel Bumper Block
643209	8	Black	Roller Adjustment Hole Plug
640631	8	Adobe Grey	Roller Adjustment Hole Plug
440031000	2	Stainless Steel	#6 x 3/4" Ph Fit Hd ScreenKeeper Installation Screw
440037018	6	Black	#8 x 1" Ph Fit Hd Panel Bumper Block Installation Screw
440026000	16	Stainless Steel	#8 x 1 1/2" Hex Hd Frame Assembly Screw
440027000	8	Stainless Steel	#8 x 2 1/2" Ph Pn Hd Keeper Installation Screw
166609	30	Black	1.25" x 0.5" x 2" Reticulated Foam Bug Sponge
600036010	6	Grey	0.625" x 1.5" x 1.188" Head / Sill Interlock Dust Plug
600037010	8	Black	0.680" x 0.635" x 0.75" Frame Jamb / Roller Track Foam Plug